

D61EX-12
D61PX-12

KOMATSU[®]

FLYWHEEL HORSEPOWER
112 kW **150 HP** @ 1850 rpm

OPERATING WEIGHT
D61EX-12: 15890 kg **35,080 lb**
D61PX-12: 18600 kg **41,010 lb**



D61EX/PX-12

CRAWLER DOZER[®]

D61EX-12, D61PX-12 Crawler Dozer

WALK-AROUND

The Komatsu S6D114E-1 turbocharged diesel engine provides an output of 112 kW **150 HP**, with excellent productivity, while meeting current emissions standards.

Left-hand **joystick** controls all tractor motion. Right-hand joystick controls all blade movements.

Gull-wing engine side doors for easy and safer servicing.

High capacity **Power Angle Tilt dozer** combines the highest power in its class with outstanding productivity.

Blade tilt lines completely protected.

Komatsu TORQFLOW transmission offers single lever control of speed (3 forward and 3 reverse) and directional changes.

Forward mounted **pivot shafts** isolate final drives from blade loads.



Electronic Monitoring System prevents minor problems from developing into major ones.

Optional hexagonal, low noise cab with viscous damping mounts provides unsurpassed operator comfort and visibility.

FLYWHEEL HORSEPOWER
112 kW **150 HP** @ 1850 rpm

OPERATING WEIGHT
D61EX-12: 15890 kg **35,080 lb**
D61PX-12: 18600 kg **41,010 lb**

BLADE CAPACITY
PAT Dozer:
D61EX-12: 3.4 m³ **4.4 yd³**
D61PX-12: 3.8 m³ **5.0 yd³**



Wet, multiple-disc brakes eliminates brake-band adjustments for maintenance-free operation.

Hydrostatic Steering System (HSS) provides smooth, quick, and powerful control in varying ground conditions.

Bolt-on sprocket for ease of maintenance.

Modular power train for increased serviceability and durability.

OPERATOR'S COMPARTMENT

All steering, direction, and speed changes are made by a left-hand single joystick control. If the operator wants to move the machine forward and to the left, he simply moves the joystick forward and to the left. If he desires a gear change, he merely twists his wrist. The machine responds to the movement of the lever providing the operator with the feeling of natural control with Komatsu's joystick.

Low-Noise Design

For smoother riding comfort, power train components and hydraulic control valves are mounted to the frame with rubber pads to soften vibration and shut out noise. Since the D61 employs joysticks, the walk-through operator compartment is uncluttered for smooth entry and exit. A suspension seat with backrest is standard equipment.

Hexagonal Pressurized Cab (Optional)

This is another added comfort feature. Air filters and a higher internal air pressure combine to prevent external dust from entering the cab. In addition, the cab's hexagonal design provides excellent front, sides, and rear visibility. Viscous damper cab suspension softens shocks for operator comfort and extends component life.



Easy-to-Operate Work Equipment Control Lever

With the Closed-center Load Sensing (CLSS) hydraulic system, blade lever stroke is directly proportional with blade speed, regardless of the load and travel speed. This results in superb, fine controllability.

Benefits of CLSS

- More precise and responsive operation due to the pressure compensation valve.
- Reduced fuel consumption by discharging only the required amount of oil from the pump.
- The work equipment moves smoothly for operations such as side-cutting even when priority is given to steering.

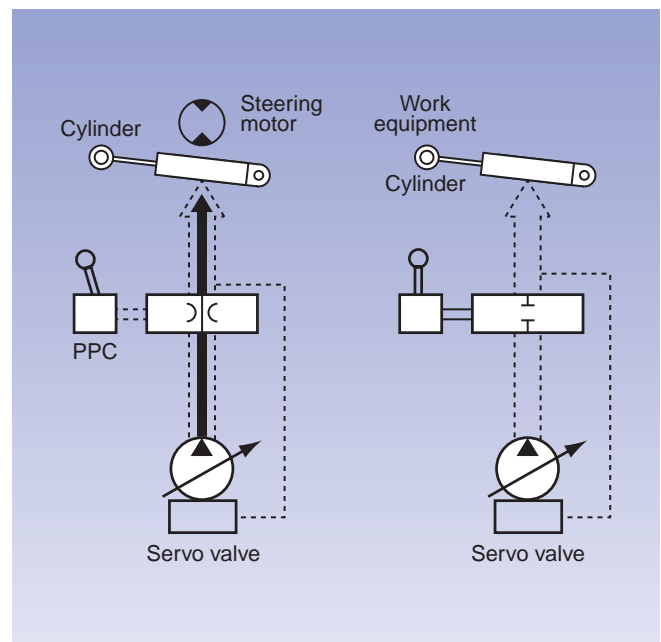

ENGINE AND TORQUE CONVERTER

Komatsu S6D114E-1 Turbocharged Diesel Engine

Powerful Engine

A powerful S6D114E-1 turbocharged diesel engine provides a massive output of 112 kW **150 HP**. The engine power is transmitted smoothly to the final drives via a high-efficiency torque converter. And this engine also meets current emissions standards, without sacrificing power or machine productivity.

Gull-Wing Engine Side Covers

With a gas-spring cylinder that opens widely, the engine and the auxiliary components can be checked easily.



Electronic Monitoring System

An electronic monitoring system prevents minor problems from developing into major ones. All meters and gauges are controlled by a microcomputer, which provides a wide indication range for an easier, more precise reading.



- Charge Lamp
- Engine Oil Pressure Caution Lamp
- Engine Water Temperature Caution Lamp
- Engine Water Temperature Gauge
- Fuel Gauge
- Intake Air Heater Lamp
- Monitor Caution Cancel Switch
- Monitor Caution Lamp
- Service Meter
- Transmission Oil Temperature Caution Lamp
- Transmission Oil Temperature Gauge
- Transmission Gear Indicator

Hydrostatic Steering System—Smooth, Powerful Turning

Komatsu's Hydrostatic Steering System (HSS) distributes power to both tracks without power interruption on the inside track. When the machine turns, the outside track moves faster and the inside slower, for smooth, powerful turns. The left and right tracks can be counter-rotated for a minimum turning radius providing excellent maneuverability. Shock-free steering reduces machine vibration and minimizes operator fatigue.

- Turning while dozing—the machine turns by driving the left and right tracks under power at different speeds allowing the machine to travel at the same speed as in straight dozing.
- Side-cutting—when side-loading the blade, straight travel can be maintained utilizing HSS.
- On downhill slopes—the machine doesn't require cross-steering. The joystick provides the same steering response on downhill slopes as on flat ground.
- Grading—can be done efficiently without damaging the ground, because the inside track is not locked during turning.
- Counter-rotates for exceptional maneuverability.

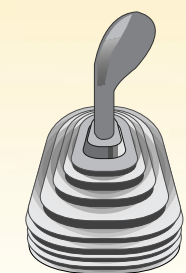
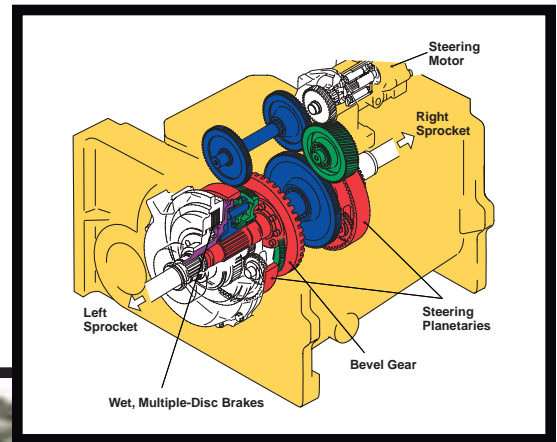

Left Hand

Steering Functions

- Forward and reverse
- Right and left steering
- First, to second, to third shifting

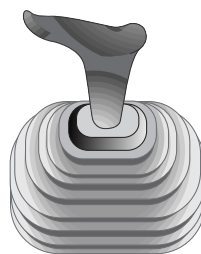

Right Hand

Blade Functions

- Lifting and lowering
- Tilting
- Left and right angling

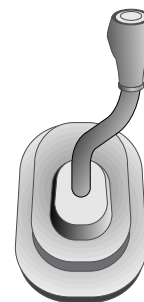

Ripper Functions (Optional)

- Raise and lower

UNDERCARRIAGE AND FRAME

Undercarriage

Low Drive and Long Track Undercarriage

Komatsu's design is extraordinarily tough and offers excellent grading ability and stability. Large-diameter bushings, increased track link heights, and improved oil seals help to increase undercarriage durability.

Improvements

Numerous improvements to increase undercarriage reliability and durability have been incorporated. Serviceability has also been improved with the addition of remote greasing of equalizer bar center pin.



Frame

Flat Bottom Frame

A **flat bottom frame**, the monocoque track frames and forward-mounted pivot shafts provide good maneuverability in muddy terrain by preventing mud from building up under the frame.

Modular-Designed Power Train Units

The modular design allows easy removal and installation of any individual unit for shorter downtime.

Wet, Multiple-Disc Brakes

Eliminates brake-band adjustments for maintenance-free operation.

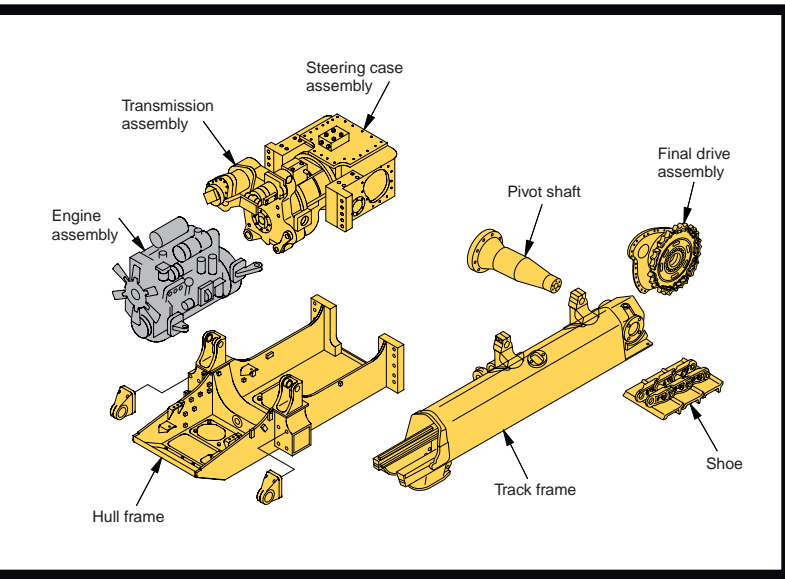

Durability

Because fewer components mean greater reliability, we've designed a **simple hull frame** made of a thick, single plate. Track frames have a large-section construction for maximum rigidity. Even the box-section construction of the blade back beam is reinforced, all with durability in mind.

Reservoir



*A **radiator coolant reservoir** makes it easier to check the coolant level and eliminates frequent refilling.*

Test Ports



***Oil pressure test ports** for the power train are centralized on the right-hand side of the operator platform for easy access.*

SPECIFICATIONS



ENGINE

Model Komatsu S6D114E-1
 Type 4-stroke cycle, water-cooled, emissionized, direct injection, turbocharged engine
 Number of cylinders 6
 Bore 114 mm **4.49"**
 Stroke 135 mm **5.31"**
 Piston displacement 8.3 ltr **506 in³**
 Gross horsepower* 123 kW **165 HP** @ 1850 rpm
 Net flywheel horsepower** 112 kW **150 HP** @ 1850 rpm
 Net maximum torque 80 kg m **589 ft lb** @ 1300 rpm

Direct injection fuel system. All-speed mechanical governor. Forced lubrication driven by gear pump. Full-flow for lube purification. Dry-type air cleaner with automatic dust evacuator and dust indicator. 11 kW/24 V electrical starter motor. 35 kW/24 V alternator. 140 Ah/2 x 12 V batteries.

* Gross horsepower output for complete engine operating under SAE J1995 conditions.

** Net flywheel horsepower output for standard engine (SAE J1349) including air cleaner, alternator (not charging), water pump, lubricating oil pump, fuel pump, muffler, and fan.



TORQFLOW TRANSMISSION

Komatsu's TORQFLOW transmission consists of a water-cooled, 3-element, 1-stage, 1-phase torque converter and a planetary gear, multiple-disc clutch transmission which is hydraulically actuated and force-lubricated for optimum heat dissipation. Joystick control of gears (3 forward and 3 reverse) and directional steering changes. Gearshift lock lever and neutral safety switch prevent machine from accidental starts.

Travel speed	Forward	Reverse
1st	0-3.5 km/h 0-2.2 mph	0-4.6 km/h 0-2.9 mph
2nd	0-6.0 km/h 0-3.7 mph	0-7.9 km/h 0-4.9 mph
3rd	0-10.3 km/h 0-6.4 mph	0-12.8 km/h 0-8.0 mph

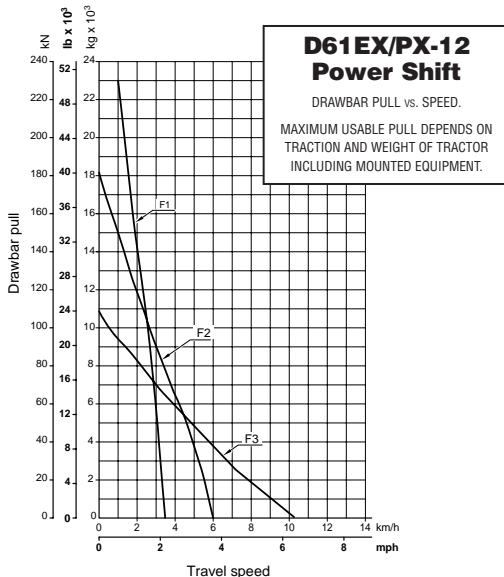

FINAL DRIVE

Spur gear double-reduction, final drives increase tractive effort. Segmented sprockets are bolt-on for easy in-the-field replacement.



STEERING

Joystick controls for all directional movements. Pushing the joystick forward results in forward machine travel, while pulling it rearward reverses the machine. Simply tilt the joystick to the left to make a left turn. Tilt it to the right for a right turn.

The Hydrostatic Steering System (HSS) is comprised of a hydraulic pump and motor. This design allows for counter-rotation under certain ground conditions. Wet, multiple-disc, pedal-controlled service brakes are spring-actuated and hydraulically-released. The directional and gear control joystick lock lever also applies the brakes.

Minimum turning radius:
 D61EX-12 1.8 m **5'11"**
 D61PX-12 2.2 m **7'3"**

As measured by track marks on ground.



UNDERCARRIAGE

Suspension Oscillation with equalizer bar and forward mounted pivot shafts
 Track roller frame Monocoque, large section, durable construction
 Number of carrier rollers (each side) 2
 Track shoes Lubricated tracks. Unique dust seals for preventing entry of foreign abrasives into pin-to-bushing clearances for extended service. Track tension is easily adjusted with a grease gun.

	D61EX-12	D61PX-12
Number of track rollers (each side)	6	8
Number of shoes (each side)	40	46
Grouser height	55.5 mm 2.2"	55.5 mm 2.2"
Shoe width (standard)	600 mm 24"	860 mm 34"
Ground contact area	31200 cm ² 4,836 in²	54524 cm ² 8,451 in²
Ground pressure	50.0 kPa 0.51 kgf/cm ² 7.25 psi	31.4 kPa 0.32 kgf/cm ² 4.55 psi
Track gauge	1900 mm 6'3"	2140 mm 7'0"
Length of track on ground	2600 mm 8'6"	3170 mm 10'5"



COOLANT AND LUBRICANT CAPACITY (REFILLING)

Coolant 44 ltr **11.6 U.S. gal**
 Fuel tank 315 ltr **83.2 U.S. gal**
 Engine oil 19 ltr **5.0 U.S. gal**
 Damper 1.3 ltr **0.3 U.S. gal**
 Transmission, bevel gear, and steering system 44 ltr **11.6 U.S. gal**
 Final drive (each side) 28.5 ltr **7.5 U.S. gal**



OPERATING WEIGHT (APPROXIMATE)

Tractor weight:
 Including rated capacity of lubricant, coolant, ROPS, full fuel tank, operator, and standard equipment.
 D61EX-12 13210 kg **29,120 lb**
 D61PX-12 15630 kg **34,460 lb**

Operating weight:
 Including power angle tilt dozer, ROPS canopy, operator, standard equipment, rated capacity of lubricant, coolant, and full fuel tank.
 D61EX-12 15890 kg **35,080 lb**
 D61PX-12 18600 kg **41,010 lb**



DIMENSIONS

	D61EX-12		D61PX-12	
A	1600 mm	5'3"	1600 mm	5'3"
B	1900 mm	6'3"	2140 mm	7'0"
C	3115 mm	10'3"	3115 mm	10'3"
D	2500 mm	8'2"	3000 mm	9'10"
E	600 mm	24"	860 mm	34"
F	390 mm	1'3"	390 mm	1'3"
G	1830 mm	6'0"	1830 mm	6'0"
H	2595 mm	8'6"	3170 mm	10'5"
I	55 mm	2.2"	55 mm	2.2"
J	3590 mm	11'9"	4160 mm	13'8"

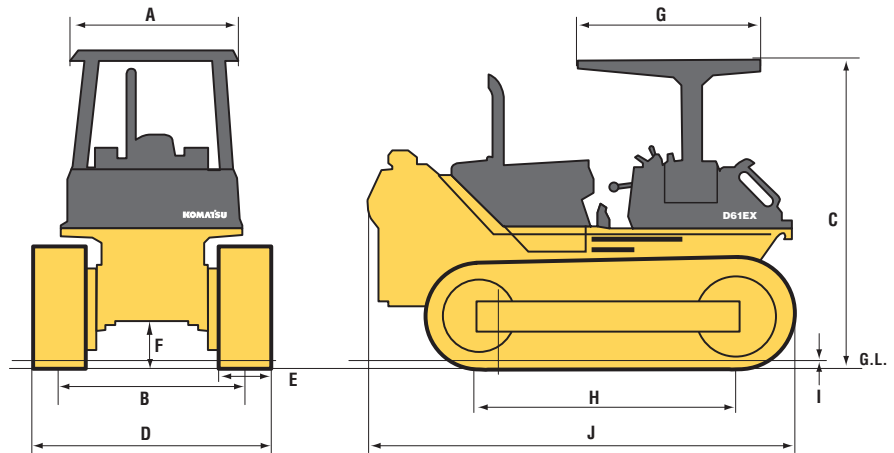

Ground clearance 390 mm 15"



HYDRAULIC SYSTEM

Closed-center Load Sensing System (CLSS) designed for precise and responsive control and for efficient simultaneous operation.

Hydraulic control unit:

All spool control valves externally mounted beside the hydraulic tank. Plunger-type hydraulic pump with capacity (discharge flow) of 174 ltr/min **46.0 U.S. gal/min** at rated engine rpm.

Relief valve setting 210 kg/cm² **2,990 psi**

Hydraulic cylinders Double-acting, piston

	Number of cylinders	Bore
Blade lift	2	110 mm 4.33"
Blade tilt	1	130 mm 5.12"
Blade angle	2	100 mm 3.94"

Hydraulic oil capacity (refilling):

Power angle tilt dozer 48.0 ltr **12.7 U.S. gal**

Control valves:

Spool control valve for power angle tilt dozer.

Positions:

Blade lift Raise, hold, lower, and float

Blade tilt Right, hold, and left

Blade angle Right, hold, and left

Spool control valve for semi-U and straight tilt dozer.

Positions:

Blade lift Raise, hold, lower, and float

Blade tilt Right, hold, and left



DOZER EQUIPMENT

Use of high tensile strength steel in moldboard for strengthened blade construction.

	Overall Length With Dozer	Blade Capacity	Blade Width x Height	Maximum Lift Above Ground	Maximum Drop Below Ground	Maximum Tilt Adjustment	Additional Weight
D61EX-12 Power Angle Tilt Dozer	5025 mm 16'6"	3.4 m ³ 4.4 yd³	3275 mm x 1365 mm 10'9" x 4'6"	915 mm 3'0"	515 mm 1'8"	510 mm 1'8"	2340 kg 5,160 lb
D61EX-12 Semi-U Tilt Dozer	5055 mm 16'7"	4.3 m ³ 5.6 yd³	3175 mm x 1300 mm 10'5" x 4'3"	965 mm 3'2"	535 mm 1'9"	600 mm 2'0"	2330 kg 5,140 lb
D61PX-12 Power Angle Tilt Dozer	5450 mm 17'11"	3.8 m ³ 5.0 yd³	3860 mm x 1200 mm 12'8" x 3'11"	1020 mm 3'4"	575 mm 1'11"	600 mm 2'0"	2630 kg 5,800 lb
D61PX-12 Straight Tilt Dozer	5300 mm 17'5"	3.8 m ³ 5.0 yd³	3860 mm x 1070 mm 12'8" x 3'6"	1125 mm 3'8"	515 mm 1'8"	600 mm 2'0"	2230 kg 4,920 lb



STANDARD EQUIPMENT FOR BASE MACHINE

ENGINE AND ITS RELATED ITEMS:

- Air cleaner, double element type
- Automatic deaeration for fuel line
- Engine, Komatsu S6D114E-1, 112 kW
150 HP, direct injection turbocharged, emission certified diesel
- Engine precleaner
- Exhaust pipe, curved
- Fan, blower

ELECTRIC SYSTEM:

- Alternator, 35 ampere, 24 V
- Back-up alarm
- Batteries, large capacity
- Lights (2 front, 1 rear)
- Starting motor 11 kW, 24 V

POWER TRAIN AND CONTROLS:

- TORQFLOW transmission, torque converter
- Hydrostatic Steering System (HSS)
- Mono-lever steering with PPC
- Sprockets, segmented, bolt-on style

UNDERCARRIAGE:

- Idler with recoil spring
- Track frames:
 - 7 roller, 2 carrier roller (D61EX-12)
 - 8 roller, 2 carrier roller (D61PX-12)

- Track roller guards, center and end section guiding guards
- Track shoe assembly, single grouser shoes with sealed and lubricated link assembly
 - D61EX-12: 600 mm 24"
 - D61PX-12: 860 mm 34"

GUARDS AND COVERS:

- Engine hood and side panels
- Fenders, standard type
- Radiator mask enclosed for sound deflection
- Rear cover, strengthened type
- ROPS mounting brackets
- Underguards, crankcase, and transmission

OPERATOR ENVIRONMENT:

- Cup holder
- High mounted footrest
- Instrument monitor panel, electronic
- Lunch box holder
- Rearview mirror
- Seat belt, 3" retractable
- Seat, suspension type, fully adjustable

HYDRAULICS AND CONTROLS:

- Accumulator for PPC
- Blade cylinder hoses, standard type
- Hydraulics for PAT dozer
- Mono-lever blade control with PPC

SPECIAL ARRANGEMENTS:

- Hard water area arrangement (corrosion resistant)
- High altitude arrangement (no fuel adjustment up to 3000 m 9,840 ft)
- Hot area arrangement: -20°C -4°F through +50°C +122°F

VANDALISM PROTECTION:

- Filler cap locks and cover locks

OTHER STANDARD EQUIPMENT:

- Marks and plates, English
- Pullhook

ROPS canopy must be ordered

Dozer assembly and rear-mounted equipment are not included



OPTIONAL EQUIPMENT

- Air conditioner with heater, defroster, pressurizer
- AR track assembly (abrasion resistant links and bushings)
- Cab attachments
- Cab, steel
- Cold weather spec
- Drawbar, rigid
- Engine side cover
- Engine protection equipment
- Fan, reversible

- Fuel hoses, non-flammable
- Heater and defroster
- Hinged, strengthened radiator mask
- Hitch
- Hydraulics for ripper
- Machine protection equipment
- Radiator core protective grid
- Radiator mask, hinged and strengthened
- Rear light, additional
- Ripper, multi-shank (fixed)
- Ripper hydraulics control unit

- ROPS canopy
- Seat, deluxe, suspension with turntable
- Sun visor
- Sweeps, front, side, rear, and door screens
- Tank guard group
- Tool kit and ordinary spare parts
- Underguards, reinforced
- Vandalism protection cover for instrument panel
- Water separator



RIPPER

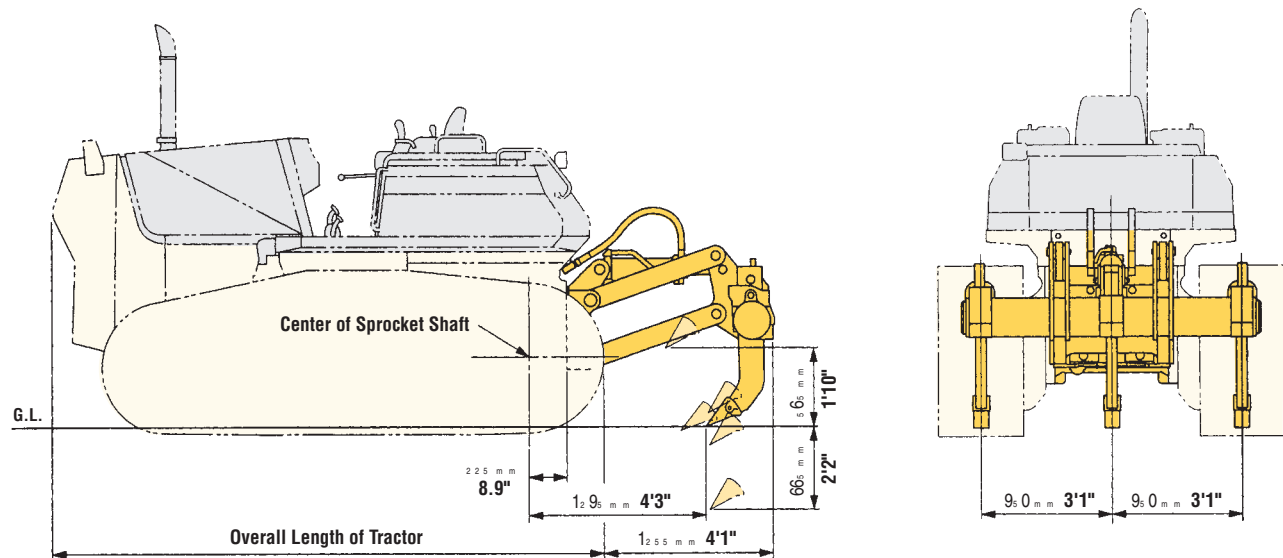

SUPPORT

Count on Komatsu and your local distributor for the support you deserve. Our success depends on satisfying your need for productive equipment and supporting that equipment. That's why we have one of the largest and strongest heavy-equipment distributor organizations in North America. Their personnel are not only trained to help you select the equipment that is best-matched for your business but to support that equipment.



Finance Through its finance company, Komatsu can offer you a wide variety of financing alternatives designed to meet your needs. Programs include municipal leases for governmental agencies, conditional sales contracts, and leases with \$1 purchase options for customers interested in owning their equipment. Ask your distributor about Komatsu leasing. We offer finance and operating leases and the unique *Advantage Lease* which offers you predetermined purchase, return, and renewal options.



Parts Three computer-linked parts distribution centers provide fast access to anywhere in the U.S. and Canada. Most parts are available overnight. Plus, Komatsu distributors keep a large assortment of commonly used parts in stock for immediate access.



Remanufactured parts Save money and still have the same warranty as new parts at a fraction of the cost with like-new remanufactured parts.



Maintenance Take advantage of the experience we have gained and ask your distributor about our factory-supported programs including: regular scheduled maintenance, oil and wear analysis, diagnostic inspections, undercarriage inspections, training, special service tools, parts programs, and even a special software program to help your distributor keep track of and manage service-related data.

KOMATSU®

Komatsu America International Company
440 N. Fairway Dr., Vernon Hills, IL 60061